



Technical Specification

1. Micro Controller Based, Double Display
2. Upper display, 7 seg, red 0.56" LED for process value sensor 1.
 Lower display, 7 seg, white 0.56" LED for process value sensor 2.
3. Dimension : Size : 96(H) X 96(W) X 54(D) mm.
 Panel Cutout : 92 X 92 mm.
4. Input : PT-100/3W & Humidity sensor (RH-100)
5. Range : PT-100 (0.0 To 400.0° C)
 Humidity (0.0 TO 100.0 % RH)
6. Supply : 100 To 270V AC, 50/60 Hz, Approx 4VA
7. Output : 2Relay 1C/O (On-Off)
8. Protection Level : IP-65 (Front side) As per IS/IEC 60529 : 2001

NOTE:

1. Make all connection properly according to 'CONNECTION DIAGRAM' given below. Then turn ON instrument. Set all parameters according to your requirement. Then press ENTER key to store new value in memory.
2. Display-1 (upper) indicates temperature value for Pt-100 and Display-2 (lower) indicates temperature value for Humidity.

Accurate Sensing of humidity is subject to proper mounting of humidity sensor as per application area. Please consult our support engineers if needed.

Connection Diagram

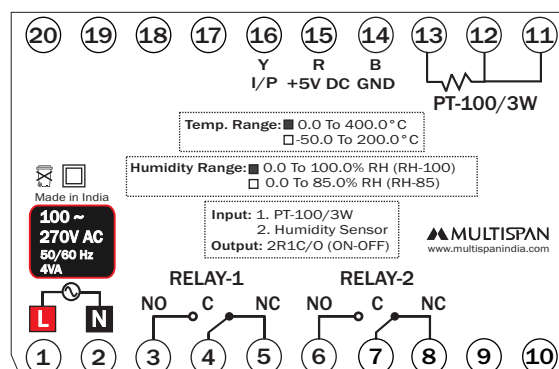

USER CONFIGURATION

Menu-1

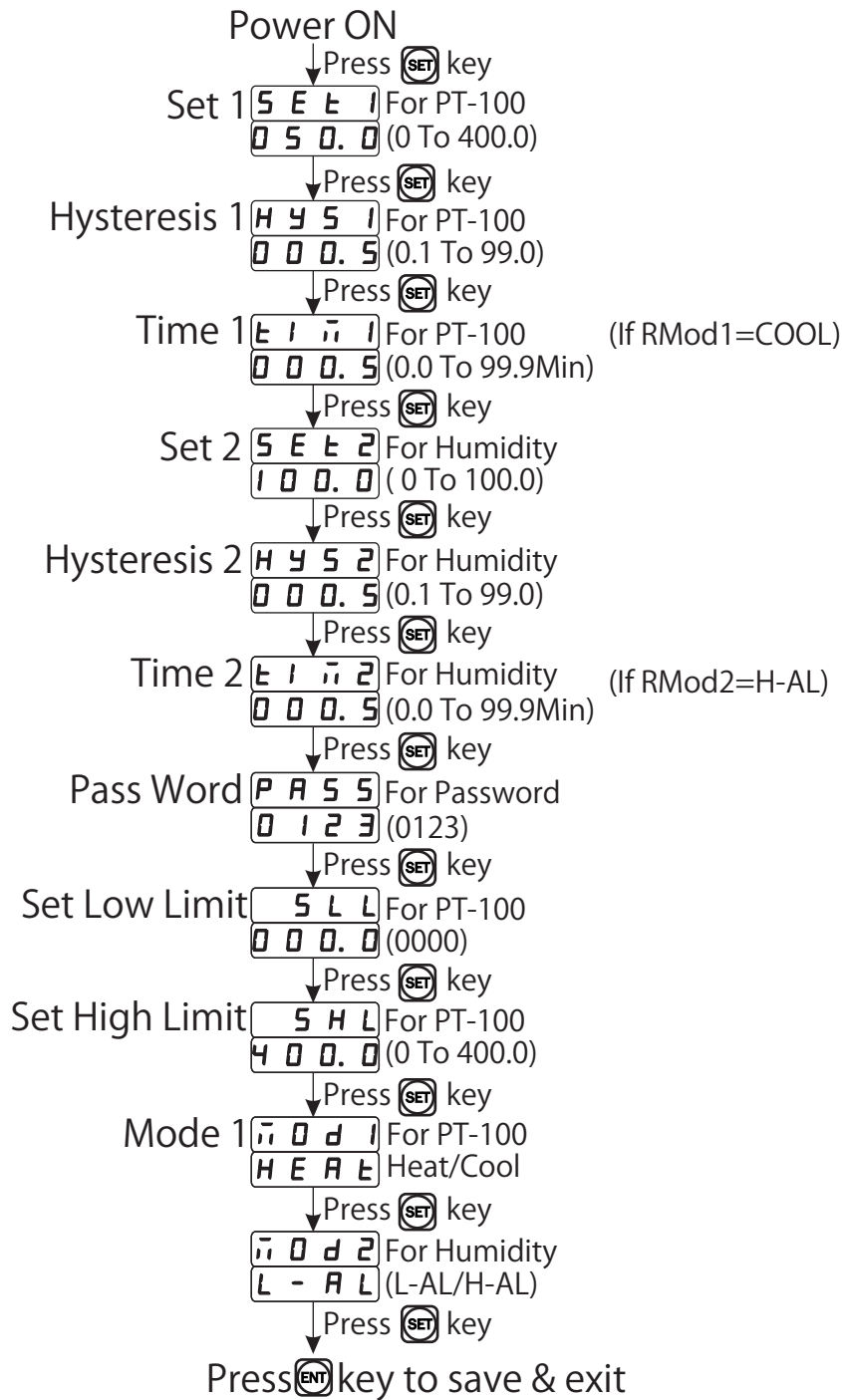

Menu-2

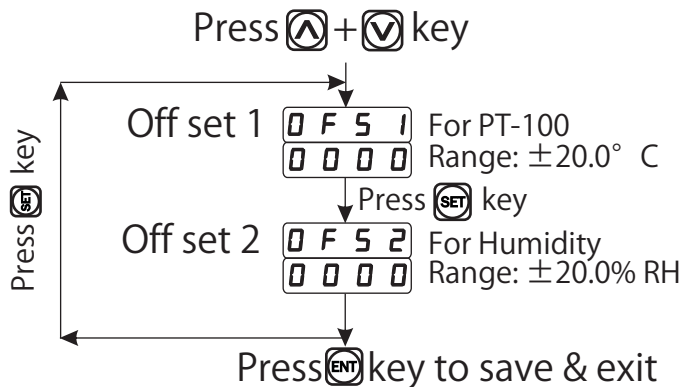

Product improvement and upgrade is a constant procedure. So for more updated operating information and support, please contact our helpline : +91-9978991474/ 76 /82 or Email at service@multispanindia.com Ver:1902